

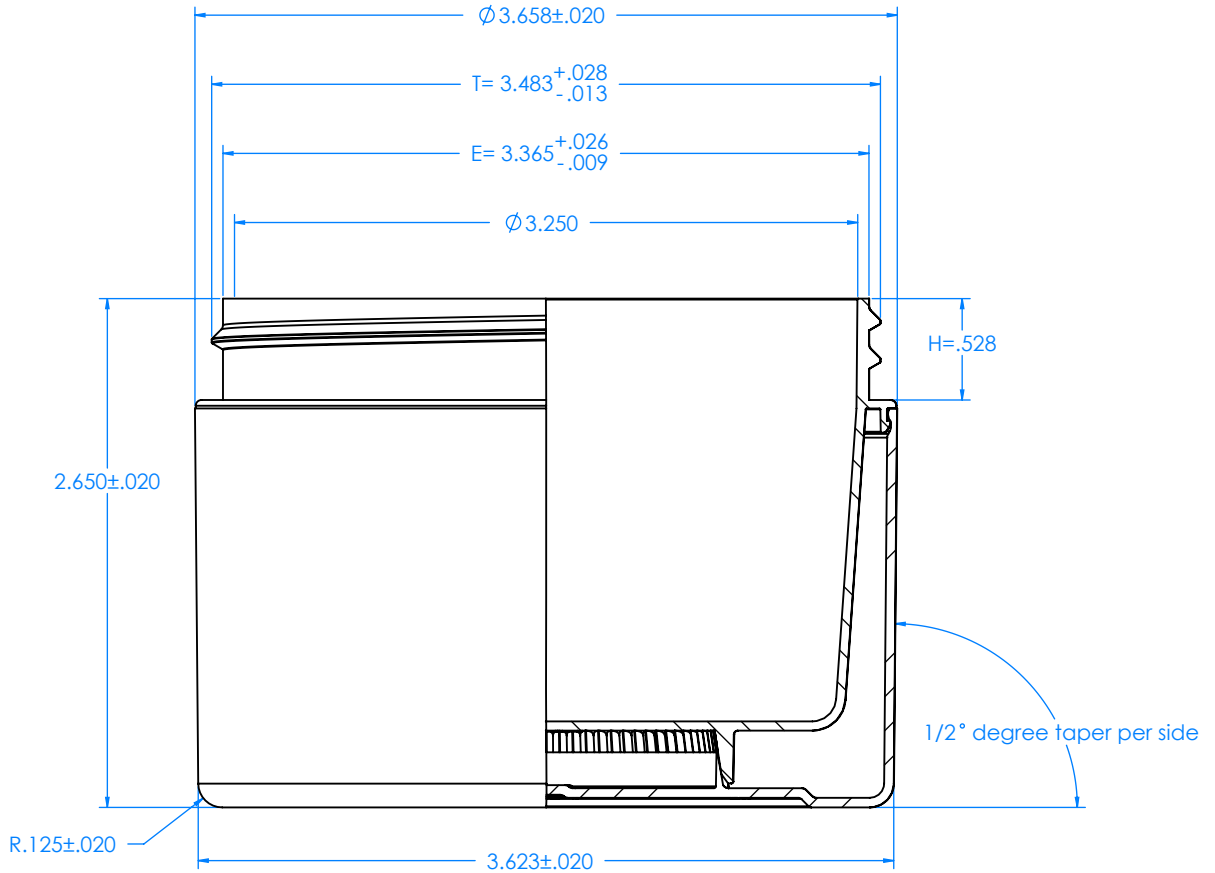

725 zwissig way
 union city, ca 94587
 phone: 866-93-taral
 www.taralplastics.com

WARNING: PROPRIETARY AND CONFIDENTIAL

THE INFORMATION CONTAINED IN THIS DRAWING IS THE SOLE PROPERTY OF TARAL PLASTICS. ANY UNAUTHORIZED USE, TRANSMISSION, OR REPRODUCTION IN PART OR AS A WHOLE WITHOUT THE WRITTEN PERMISSION OF TARAL PLASTICS IS STRICTLY PROHIBITED.



DECORATION AREA
 WRAP: 11.24 inch
 HEIGHT: 1.64 inch
 DRAFT: 1/2° per Side

REVISIONS				UNLESS OTHERWISE NOTED DIMENSIONS ARE IN INCHES TOLERANCES ARE:		MATERIAL:	POLYPROPYLENE	PART DESCRIPTION:		
REV.	DATE	DESCRIPTION	BY	DIM.	TOL.	APPROX WEIGHT:	50 grams	8oz 89mm Double Wall Jar- Straight Base PP		
				.00	.030	APPROX OVERFLOW:	285 ml			
				.000	.020	THREAD:	5 T/In PITCH			
COMMENTS: MADE IN U.S.A.				DRAWN BY: D.T. APPROVED BY: C.M.		DATE: 07/20/2015		PART CODE: 8-89-DS-PP	REV. A	SIZE A
SCALE: 1:1								DO NOT SCALE DRAWING		SHEET 1 OF 1